

FAS 2

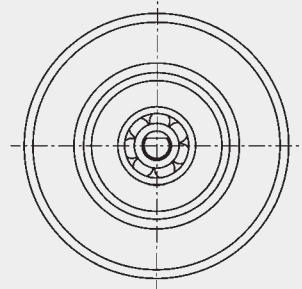

FRAS 2

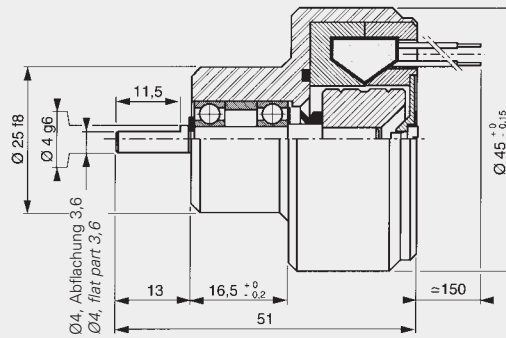
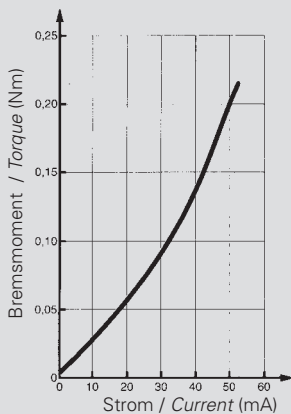
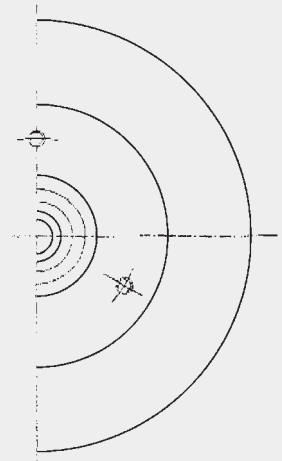
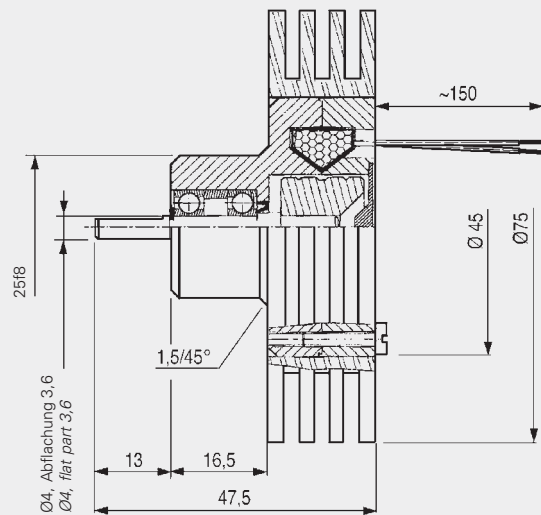

Technische Daten	Specifications		FAS 2	FRAS 2
Nennmoment	Nominal torque	(Nm)	0,20	0,20
Kleinstes Moment	Minimal torque	(Nm)	0,007	0,007
Spulenwiderstand	Coil resistance	(Ω)	195	195
Gleichstrom/Nennwert	Rated current DC	(A)	0,05	0,05
Trägheitsmoment	Rotor inertia	(kg·m ²)	0,8·10 ⁻⁶	0,8·10 ⁻⁶
Minimale Drehzahl	Min rotation speed	(min ⁻¹ /rpm)	60	60
Maximale Drehzahl	Max rotation speed	(min ⁻¹ /rpm)	3000	3000
Maximale Außentemperatur im Dauerbetrieb	Rated outside body temperature	(°C)	90	90
Höchstzulässige kurzzeitige Betriebstemperatur	Ultimate outside body temperature	(°C)	110	110
Einschaltzeit/Nennmoment	Switch-on time/nominal torque	(ms)	44	44
Ausschaltzeit/Restmoment	Switch-off time/min. torque	(ms)	27	27
Gewicht	Weight	(kg)	0,2	0,3
Wärme-Verlustleistung 100% Betrieb	Heat dissipation continuous sustained	(W)	15	25

Die Bremsen sind ausgelegt für einen Temperaturbereich von -20 bis +90 °C.
The brakes are designed for a temperature range of -20 to +90 °C.