

Bremsen mit Welle *External Shaft Brakes*

FAS 21

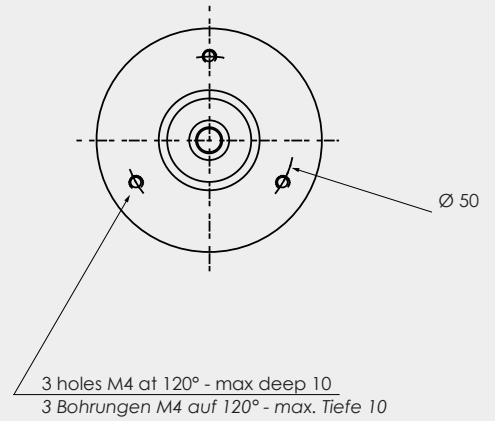

FRAS 21

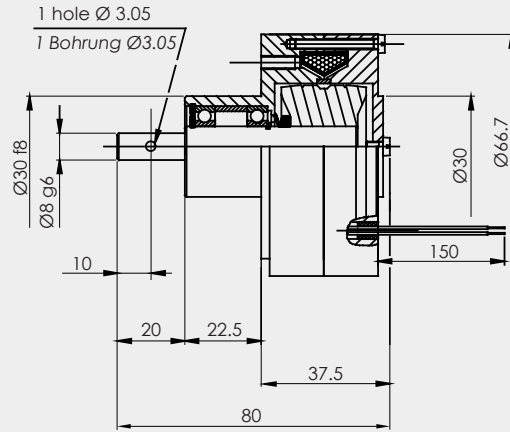
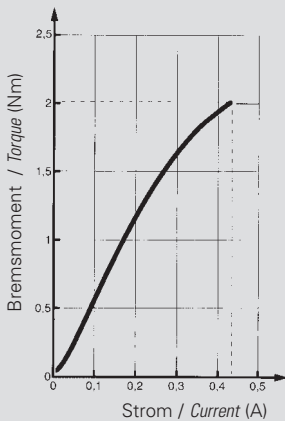
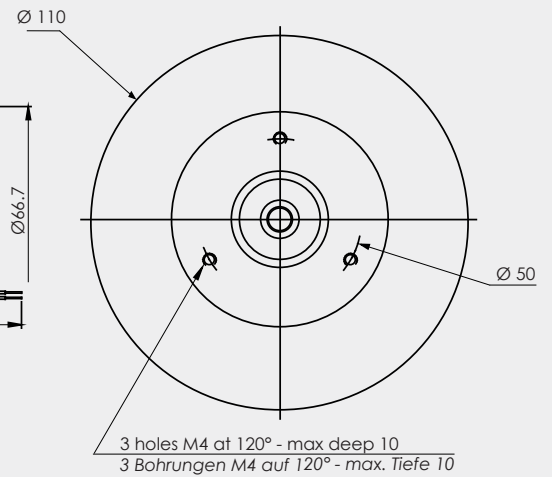
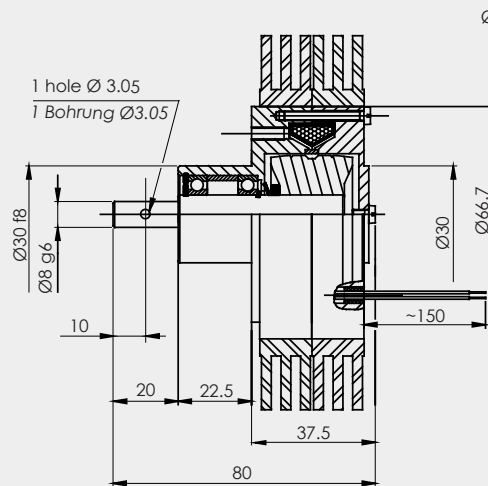

Technische Daten		Specifications	FAS 21	FRAS 21
Nennmoment	Nominal torque	(Nm)	2	2
Kleinstes Moment	Minimal torque	(Nm)	0,04	0,04
Spulenwiderstand	Coil resistance	(Ω)	31	31
Gleichstrom/Nennwert	Rated current DC	(A)	0,45	0,45
Trägheitsmoment	Rotor inertia	(kg·m ²)	0,35·10 ⁻⁶	0,35·10 ⁻⁶
Rotorgewicht				
Minimale Drehzahl	Min rotation speed	(min ⁻¹ /rpm)	60	60
Maximale Drehzahl	Max rotation speed	(min ⁻¹ /rpm)	3000	3000
Maximale Außentemperatur im Dauerbetrieb	Rated outside body temperature	(°C)	90	90
Höchstzulässige kurzzeitige Betriebstemperatur	Ultimate outside body temperature	(°C)	110	110
Einschaltzeit/Nennmoment	Switch-on time/nominal torque	(ms)	130	130
Ausschaltzeit/Restmoment	Switch-off time/min. torque	(ms)	60	60
Gewicht	Weight	(kg)	0,9	1,2
Wärme-Verlustleistung 100% Betrieb	Heat dissipation continuous sustained	(W)	35	60

Alle Maße und Daten können technischen Änderungen unterliegen und sind deshalb ohne Gewähr.
All dimensions and data may be subject to technical changes and are therefore without guarantee.