

Bremsen mit Hohlwelle *Through Shaft Brakes*

FVAT 1200 FVRAT 1200

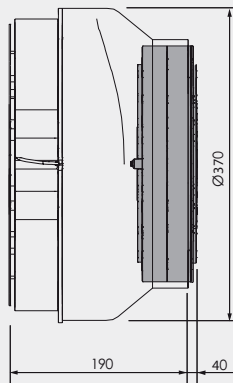

FVAT 1200
(mit Axiallüfter) 24 V DC
(with axial fan) 24 V DC



FVRAT 1200
(mit Radiallüfter) 230 V AC
(with radial fan) 230 V AC

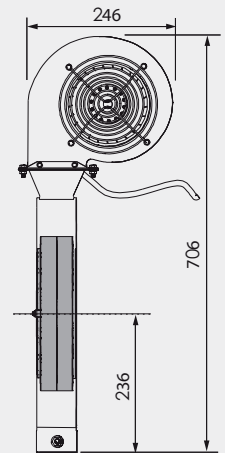

VR 1200/2002 Radiallüfter *Radial Fan Cooling Unit*

Anwendung
Diese Kühleinheit wird mit drei Schrauben M6x16 DIN 912 und Ø6 Unterlegscheiben zur Befestigung am Bremsenkühler ausgeliefert.
Utilization
This cooling unit is delivered with three screws M6x16 DIN 912 and Ø6 washers to be fixed on the brake's heater.

Technische Daten / Specifications

Spannung	Voltage	(V)	230
Frequenz	Frequency	(Hz)	50
Leistung	Power	(W)	242
Gewicht	Weight	(kg)	5,5
Stromstärke	Amperage	(Amp)	1,1
Lautstärke	Sound Level	(dBa)	67
Absicherung	Protection Level		IP44

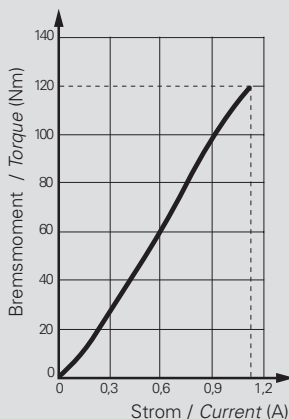
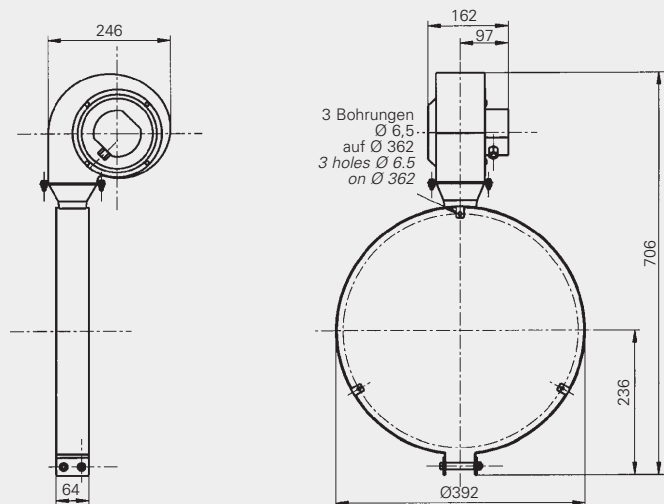

Technische Daten Specifications

			FVAT 1200	FVRAT 1200
Nennmoment	Nominal torque	(Nm)	120	120
Kleinstes Moment	Minimal torque	(Nm)	1,20	1,20
* Kleinstes Moment RR	Minimal torque RR	(Nm)	2,40	2,40
Spulenwiderstand	Coil resistance	(Ω)	12,50	12,50
Gleichstrom/Nennwert	Rated current DC	(A)	1,10	1,10
Trägheitsmoment Rotorgewicht	Rotor inertia	(kg·m ²)	26,5·10 ⁻³	26,5·10 ⁻³
Minimale Drehzahl	Min rotation speed	(min ⁻¹ /rpm)	60	60
Maximale Drehzahl	Max rotation speed	(min ⁻¹ /rpm)	2000	2000
Maximale Außentemperatur im Dauerbetrieb	Rated outside body temperature	(°C)	90	90
Höchstzulässige kurzzeitige Betriebstemperatur	Ultimate outside body temperature	(°C)	110	110
Einschaltzeit/Nennmoment	Switch-on time/nominal torque	(ms)	760	760
Ausschaltzeit/Restmoment	Switch-off time/min. torque	(ms)	685	685
Gewicht	Weight	(kg)	28,0	30,5
Wärme-Verlustleistung 100% Betrieb	Heat dissipation continuous sustained	(W)	1400	2000

Die Bremsen sind ausgelegt für einen Temperaturbereich von -20 bis +90°C.
The brakes are designed for a temperature range of -20 to +90°C.