

LC 50 LC 100

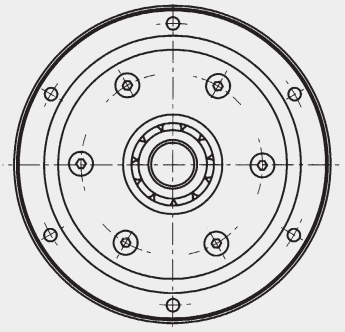

LC 150 LC 300 LC 500 LC 700

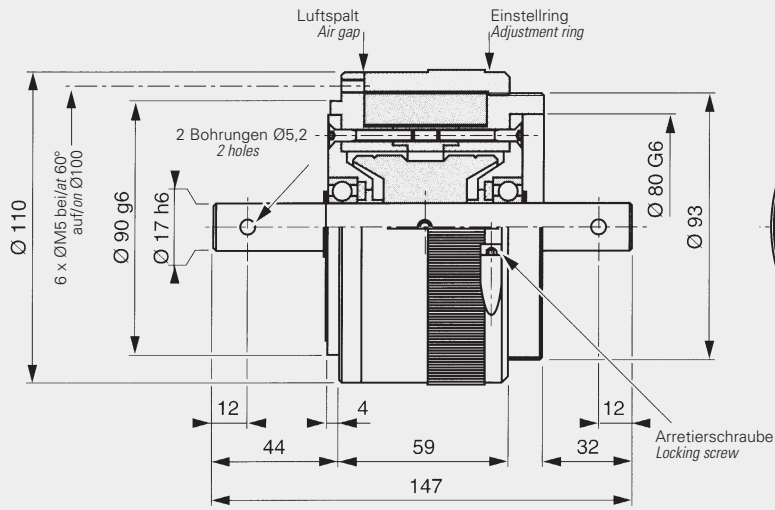
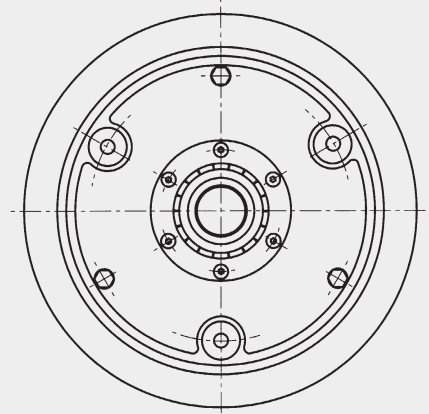
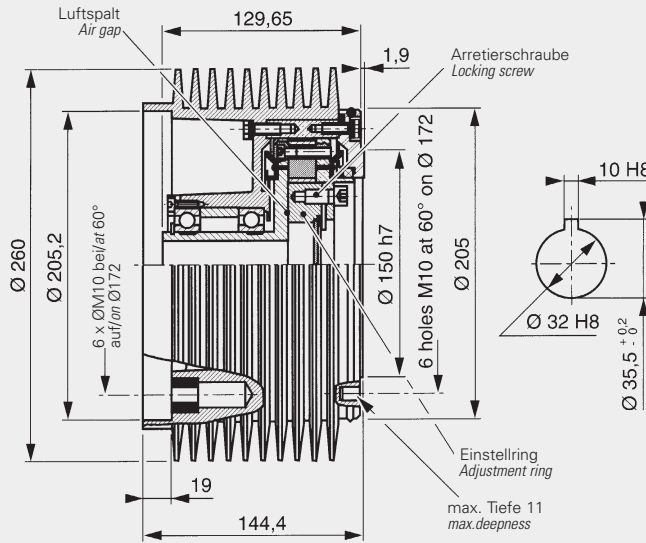
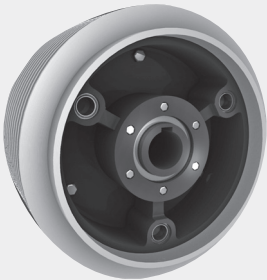

Technische Daten Specifications

			LC 50	LC 100	LC 150	LC 300	LC 500	LC 700
Übertragungsmoment	Transmission torque	(Nm) min.	2	4	5	15	25	30
		max.	6	12	15	40	65	85
Internes Trägheitsmoment	Internal rotor inertia	(kg·m ²)	2,1 · 10 ⁻⁴	2,1 · 10 ⁻⁴	23 · 10 ⁻³	23 · 10 ⁻³	23 · 10 ⁻³	23 · 10 ⁻³
Externes Trägheitsmoment	External rotor inertia	(kg·m ²)	60 · 10 ⁻⁴	60 · 10 ⁻⁴	120 · 10 ⁻³	120 · 10 ⁻³	120 · 10 ⁻³	120 · 10 ⁻³
Gewicht	Weight	(kg)	4,5	4,5	13	13	13	13
Wärme-Verlustleistung	Heat dissipation	(W)	75	75	500	500	500	500